

Important Steps

DECK PREPARATION

A stable roof deck is an essential part of the roof structure. It must be firm, smooth and provide an adequate base for nailing.

VENTILATION

Condensation can cause serious damage to shingles, the roof deck and insulation. Attic spaces must be properly ventilated. Poor ventilation can cause premature deterioration of the shingles.

FLASHINGS

Most roofs have joints and breaks such as valleys, dormers, chimneys, vents, etc.. Care must be taken that flashings are waterproof to avoid leakage at these danger points.

SHINGLE APPLICATION

Alignment must be accurate and nailing must be performed as directed for asphalt shingles to provide their full potential in appearance and performance.

Care and Handling of Materials

Asphalt shingles should be stacked only on smooth, even surfaces to avoid damaging the bottom shingles in the stack. They should be stacked no more than 15 bundles high, as too great a weight on the lower shingles may cause sticking in the bundle and bleeding of the asphalt coating through the granule surfacing. If stored outside, they should be protected from the weather, and in summer from the direct heat of the sun. Please use caution when stacking bundles on sloped roofs. Never apply asphalt shingles to roof slopes less than 2:12.

Roll roofing must always be stored on its end and never be allowed to lie on its side which would cause distortion and possible sticking in the roll. Care must be taken to avoid damage to the ends of the roll. Before using roll roofing, it must be unrolled flat then cut into convenient lengths of 12' to 18' (3.5 m to 5.5 m) and laid out in a warm place until completely relaxed and flattened out. In cold weather, stand roll roofing in a warm place until pliable before unrolling.

Bituminous roof coatings, cements and adhesives tend to stiffen when cold. Before applying in cold weather, they should be kept in a warm place until readily workable.

Roof Deck Preparation

NEW WORK

The deck must be smooth, firm and dry. Plywood [(min. 1/2" (12 mm))] is recommended for best roof performance. Board decks should be covered with a layer of plywood sheathing [min. 1/4" (6 mm)] to reduce shingle buckling. Buckling is not covered by our Limited Material Warranty.

Note:

Unless the roof deck is to be shingled immediately, it should be protected from the weather, as the drying and shrinkage of a roof deck which has been shingled wet will buckle and twist the shingles. Use a single layer of asphalt felt lapped 2" (50 mm) and nailed sufficiently to hold in place.

REROOFING

Old asphalt shingles or old roll roofing need not be removed providing the strength of the old roof structure is not impaired and is adequate for the additional weight, and providing there is sufficient nail holding power in the old roof to hold the new shingles. If the old roofing is removed, the deck is repaired and application of the roofing follows that described for new work.

If the old roofing remains in place, nail down or cut away all loose, curled or lifted shingles; remove all loose or protruding nails and sweep surface clean. For old roll roofing, slit all buckles and nail down smoothly; remove all loose and protruding nails and sweep surface clean.

METAL DRIP EDGE

For efficient water shedding at the roof's edges, particularly when no eavestrough is used, it is suggested that a metal drip edge be installed directly on the wood deck at eaves and over the underlay along the rakes. This should be of corrosion resistant sheet metal with a 2" (50 mm) to 4" (100 mm) roof flange and bent downward over the edges. It should be set on the deck into a band of asphalt plastic cement and nailed along the back edge of the flange at not more than 16" (400 mm) intervals.

Ventilation

To remove excess attic heat during the summer and excess water vapor during the winter, proper ventilation should be installed. The net free area of ventilation should be at least 1/300th of the horizontal projection of the roof area. (Some roof designs i.e., low slope roofs and cathedral ceilings may require a 1/150 ratio). For maximum effectiveness, the ventilation system should be balanced. Half of the net free ventilating area should be located in the soffits. The other half should be at or near the ridge. Venting at the soffits and at the ridge should be spread as uniformly as practical. Ensure ventilation airways are not obstructed by insulation, and that ventilation meets local building code requirements also.

Eave Protection

For ice dam protection, install an eave flashing to cover the roof deck from the eave to at least 12" (300 mm) beyond the inside wall line, or at least 36" (900 mm) from the eave, whichever is greater (for areas subject to severe icing and frequent freeze/thaw cycles, we recommend a minimum of 24" (600 mm) beyond the inside wall line). One of IKO's Ice And Water Protection products - ArmourGard, GoldShield, or Protecto is recommended, applied in accordance with the directions printed on each box. Alternatively, No. 25 Glass Base Sheet may be used, laid with at least 4" (100 mm) head lap and end laps cemented with asphalt cement; if more than one course is necessary, the lap must be outside the exterior wall line. Or, cement two layers of felt underlay together using asphalt cement.

Note

Eave protection is not required on roofs over unheated buildings such as carports, porches, etc..

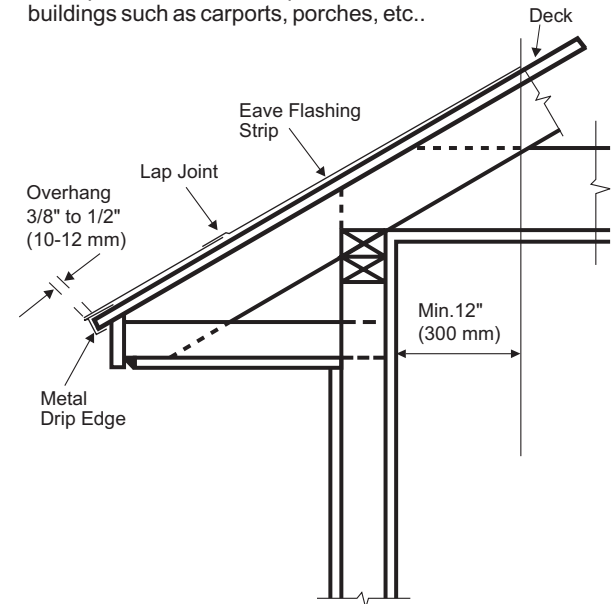

Underlayment

For glass fiber shingles below 8:12 slope, apply 1 ply of an approved underlayment parallel to eaves over that portion of roof deck not already covered by eave protection with a 2" (50 mm) head lap and 4" (100 mm) end lap and nail sufficiently to hold in place until shingles are applied. Underlayment is also required beneath some organic shingles when applied on roof slopes 6:12 to 4:12 (see individual shingle application instructions).

Valleys

A valley exists where two slopes of a roof join at an interior angle so that run-off is toward and down the join. Valleys should be constructed after eaves flashing and underlayment, but before shingles are applied.

OPEN METAL VALLEY

For longer roof performance, metal valleys are recommended. Complete valley flashing before shingles are applied. Center a 36" (900 mm) width strip of smooth surface roll roofing or one of IKO's Ice And Water Protection products - ArmourGard, GoldShield, or Protecto (A) in the valley. Ensure flashing is tight to the deck, then fasten with only enough nails to hold in place, nailing at the edges only. Center a minimum 24" (500 mm) wide, minimum 28 gauge pre-finished/galvanized metal valley liner (B) in the valley, and fasten with only enough nails to hold in place, nailing at the edges only. Snap two chalk lines (C) the full length of the valley, 6" (150 mm) apart at the top and increasing in width 1/8" (3 mm) per foot towards the bottom. When the shingles are being applied, lay them over the valley flashing, trim the ends to the chalk line, and cut a 2" (50 mm) triangle off the corner to direct water into the valley (D). Embed the valley end of each shingle into a 3" (75 mm) band of asphalt plastic cement (E), and nail the shingles 2" (50 mm) back from the chalk line.

Closed cut or woven valleys may also be acceptable. See shingle package for details.

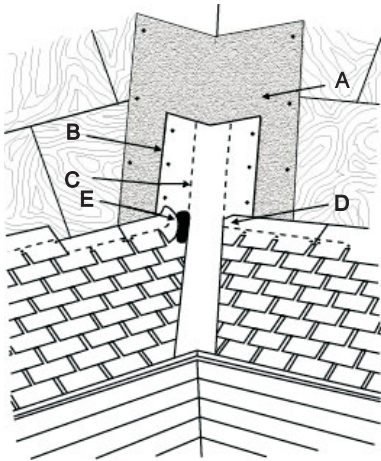

Flashings - Chimney

Since chimneys are sometimes built on foundations which are separate from the house proper, some differential settlement may occur. To avoid possible fracturing or cracking of materials at this junction, base flashings are secured only to the deck and separate cap flashings are fixed only to the chimney. To direct water around larger chimneys, a wooden cricket or saddle is built on the deck before the felt underlayment is applied. One of the most common flashings is made of sheet metal. Whether or not a cricket is needed depends on the size of the chimney (see National Building Code).

Shingles are laid up to the chimney. The low-side metal base flashing is applied by concealed cleatnailing the lower portion over the shingles. The upper portion metal base flashing covering the saddle is installed. Side flashings are then applied in conjunction with shingle application (1). As each course of shingles is laid, an 8" (200 mm) x 8" (200 mm) (or larger), metal "soaker" is applied - 4" (100 mm) over the shingle and 4" (100 mm) up the chimney. Nail through the metal and underlying shingle so that the nail head is well covered by the next shingle course. The trimmed shingles overlapping the metal are embedded in a 3" (75 mm) band of asphalt plastic cement. Particular care is taken to make the chimney corners tight against the flow of water. Cap flashing (2) is then installed into mortar joints and down over base flashing (3).

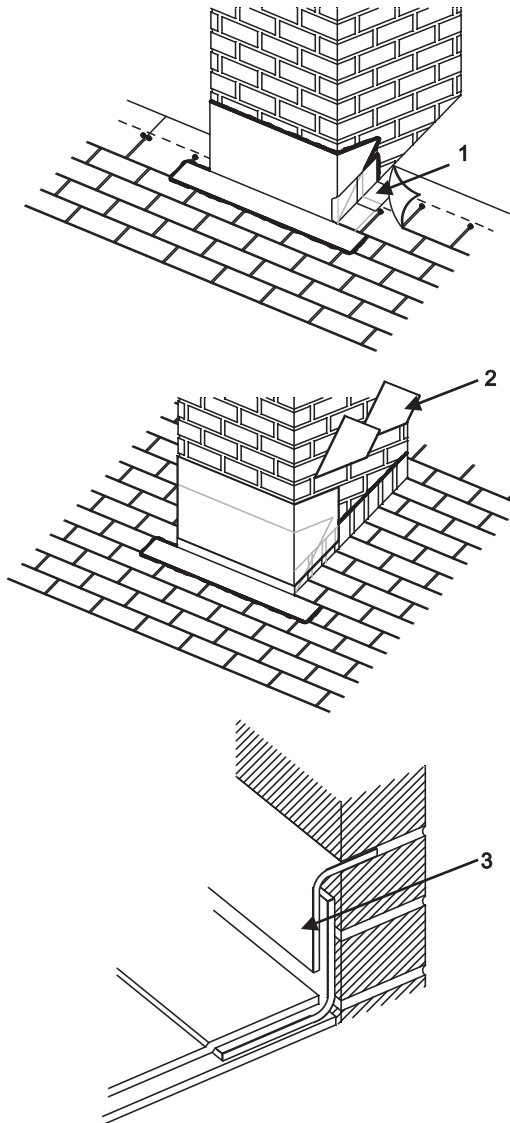

Flashings - to Vertical Wall

The drawing below illustrates the preferred method. The shingles overlapping the flashing should be well embedded in asphalt plastic cement and the wall cladding should completely cover the top of the flashing.

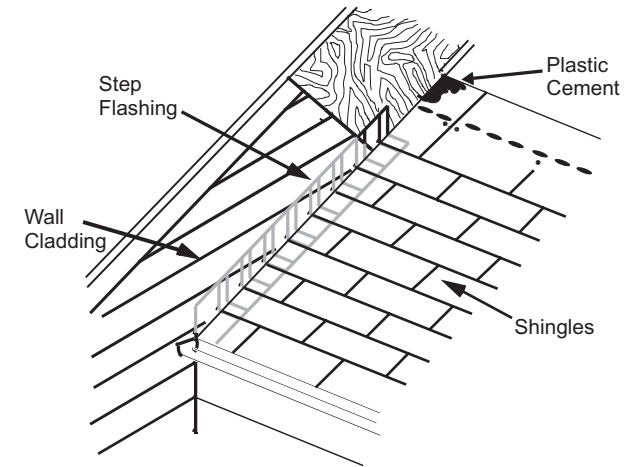

Flashings - Vent Pipes

The diagram below illustrates one of the best methods. The flange is set into a thin coat of asphalt plastic cement and nailed sufficiently to hold in place. Shingling is then continued up the roof. Where the flange is covered by the roofing, the shingles are embedded in asphalt plastic cement.

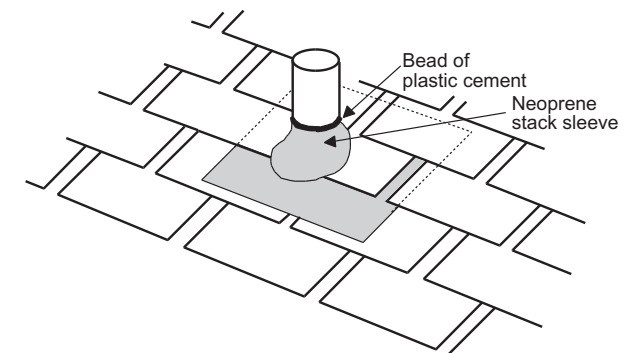

Shingle Application

NAILS

Use only hot dipped, galvanized roofing nails, 10 to 12 gauge, with not less than 3/8" (10 mm) diameter heads, long enough to penetrate at least 3/4" (20 mm) into roof deck.

For new work - 1" (25 mm) long, 1/2 lb.(227 g)/ bdl.
Over old asphalt shingles - 1-1/2" (38 mm) long, 3/4 lb.(340 g)/bdl.
Over old wood shingles - 1-3/4" (45 mm) long, 1 lb.(454 g)/bdl.

Drive nails straight with heads in firm contact with the surface of the shingle, but not so hard as to tear or fracture the shingle. Nail consecutively across the shingle or drive inner nails first. Never nail shingle ends first. Use 4 nails per shingle, except for slopes of 60° (21:12) or steeper which require 6 nails per shingle. Use of 6 nails is also recommended for steep slopes and high wind areas and winter applications. See diagram below.

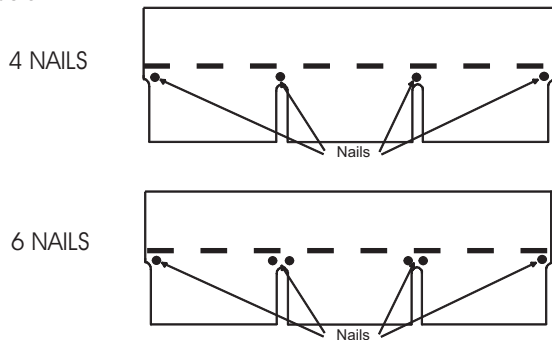

CHALK LINES

Since slight variations in the dimensions of asphalt shingles are unavoidable, sufficient chalk lines should be struck to ensure accurate vertical and horizontal alignment of shingles. Vertical lines every 4 or 5 shingle lengths are recommended. The number of horizontal lines needed will depend on the skill of the applicator in keeping horizontal alignment straight. Remember that shingle courses on either side of a dormer must meet accurately above the dormer.

COLOR MATCHING

To minimize an appearance of color shading, use shingles of the same production date (this code appears on the side of the bundle), use shingles of the same blend code (letter and two digits appearing immediately after the color on the side of the bundle), intermix shingles from different bundles, following recommended application patterns and avoid blocking. Avoid mixing different lot numbers on any one roof elevation. Also, an appearance of color variation in a newly applied roof, particularly in a dark solid color, can result from the backing material on a shingle having transferred or rubbed off on the face of the next shingle while the shingles were in the bundle. This will wash off naturally with a few rains and sunlight.

Where and How to Start a Roof

For a broken roof section, start laying shingles at a rake edge and work toward a valley or dormer. For unbroken sections, start from the most visible rake edge. If each rake is equally visible, and on hip roofs, start at the center of the section and work outwards.

STARTER COURSE

The purpose of the starter is to provide a back-up for the first course of shingles and to fill in the spaces between the cutouts. Cut approximately 3" (75 mm) off the first starter shingle to ensure that the cutouts in first course shingles are not placed over starter strip joints. Remove the exposed tab portion of shingle and apply with sealing strip adjacent to the eave edge, overhanging eaves and rake edges by 3/8" (10 mm) to 1/2" (12 mm) and nail in place. Alternately, IKO's Leading Edge shingles may be used for the starter course.

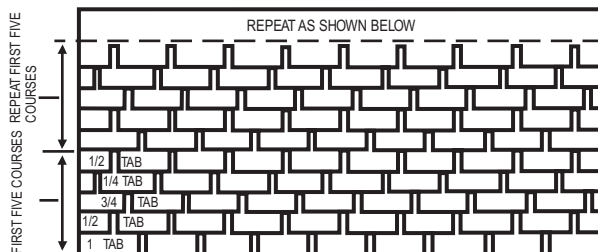

RANDOM SPACING (PREFERRED METHOD)

Random spacing can be achieved by removing different amounts from the rake tab of succeeding courses in accordance with the following general principles:

1. The width of any rake tab should be at least 1/4 tab.
2. Cutout centerlines of any course should be located at least 1/4 tab laterally from the cutout center line in both the course above and the course below.
3. The rake tab widths should not repeat closely enough to cause the eye to follow a cutout alignment.

CAUTION

Wear soft rubber-soled shoes to avoid scuffing the shingles.

SEALING DOWN TABS

When climate, weather or job conditions are such that the asphalt adhesive on the shingles may not be effective and when shingles are used in high wind areas, shingle tabs should be sealed down to prevent damage from repeated lifting and fluttering in the wind. Use a spot of asphalt plastic cement, 1" (25 mm) in diameter applied with a caulking gun or putty knife under each tab, located 1" (25 mm) above the cutout in the underlying shingle. Do not use too large a spot of cement, since evaporation of the volatile solvent in the cement could migrate through the shingle tab, dissolving its asphalt content and causing it to blister.

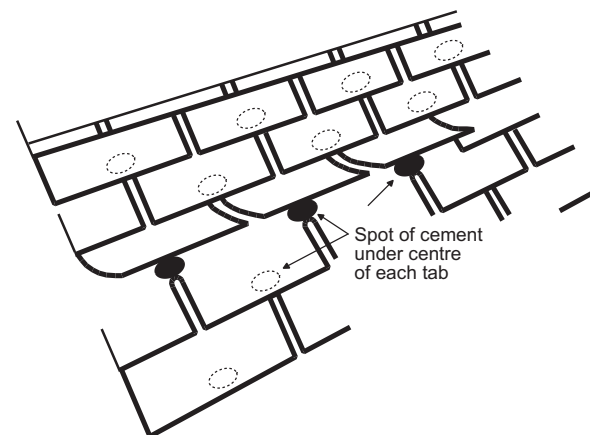

This procedure is especially recommended for all installations in high wind areas for the top five courses of shingles immediately below any roof ridge, which are usually most susceptible to wind uplift.

On slopes steeper than 60° (21:12) from the horizontal, shingle tabs must be sealed as described above, since contact between the tabs and the underlying course is insufficient for the self-seal adhesive to be effective.

Do not remove the plastic strips from the shingles' underside. Its only purpose is to prevent the shingles from sticking together in the bundle. It serves no purpose once the shingles have been applied.

Low Slope Application

Standard three-tab shingles may be applied conventionally, providing tabs are adequately sealed against wind lift, and special underlayment is used.

For best low slope roof waterproofing performance, IKO recommends covering the entire low sloped area with one ply of one of IKO's Ice And Water Protection products - ArmourGard, GoldShield, or Protecto, applied with a 3" (75 mm) lap and 6" (150 mm) endlaps. Once the IKO Ice And Water Protection product is laid down over the entire low sloped area, the three-tab shingles can be applied according to their normal application procedures. IKO's Ice And Water Protection products are excellent for this type of application since they seal around the shanks of the penetrating fasteners, preventing leakage which may result from ice backup or wind-driven rain. Caution: IKO's Ice And Water Protection products are vapor barriers, so if used on entire roof areas, thorough ventilation must be ensured to avoid condensation beneath the roof deck.

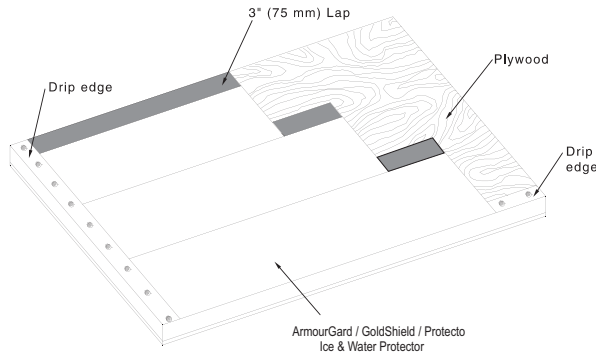

The shingles are then applied over the underlayment in the same manner as described for normal slopes, except that extra care must be taken to ensure that tabs are adequately sealed down, since the angle of the wind against a low slope roof can cause tabs to lift more easily than on a normal slope.

(Note: Two layers of No. 15 plain felt is also acceptable as an underlay in low sloped roof areas. The felt plies should be cemented together from the eave up to a point at least 24" beyond the inside wall line.)

Hip and Ridge Areas

Use individual shingles cut from 3-tab strip shingles by dividing at the cutouts. Bend each resulting tab down the center and apply over hips and ridges, exposing 5-5/8" (143 mm) of each shingle to the weather. Nail 6" (150 mm) back from the exposed end, 1" (25 mm) in from each side. Start hips at the bottom and work up. Start ridge at the end away from the prevailing wind direction and work back. Note: For some products, doubling of ridge caps is suggested; check shingle bundle wrapper application instructions for details.

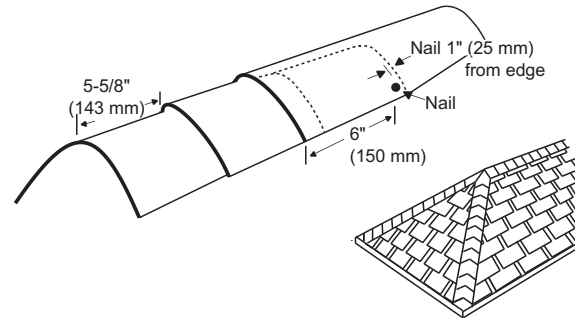

Take Care of Your New Roof

Keep roof surfaces clear of leaves, twigs and other litter. Keep eavestroughs and downspouts clean and unobstructed so that water will drain freely.

Keep the trees trimmed to avoid branches touching the shingles or falling on the roof. Vines should never be allowed to spread onto the shingles.

Avoid walking on asphalt shingles. When necessary to go up on the roof, use ladders or other suitable safety equipment.

The information herein is provided in good faith. However, since methods and conditions of application and use are beyond our control, we will not be responsible for product performance when not used according to our current directions and specifications. Some of our shingle designs may require unique application procedures. Consult shingle packaging for details.

IKO INDUSTRIES LTD.	
71 Orenda Road	
Brampton, ONT. L6W 1V8	
Tel (905) 457-5321	Fax (905) 457-3196
WESTERN CANADA	1-800-661-1034
EASTERN CANADA	1-800-268-0878
UNITED STATES	1-800-387-2318



Guide To Good Roofing

Application of 3-tab asphalt shingles

